

下面框图远离数字信号布线、高频、大电流、电源、电源插座、继电器等

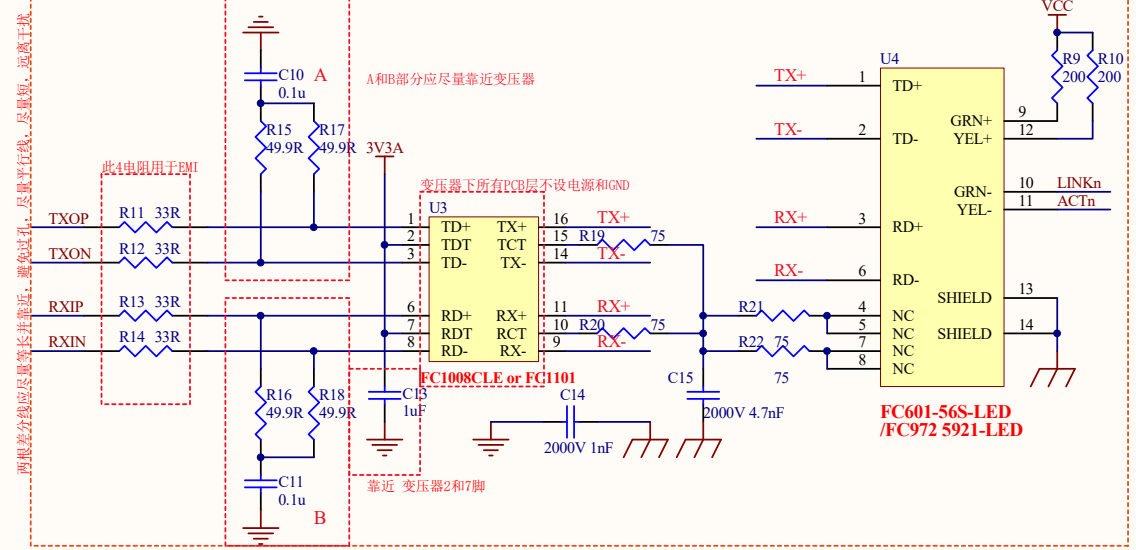

浩然电子可配套提供工业级变压器&RJ45座和晶振等核心器件

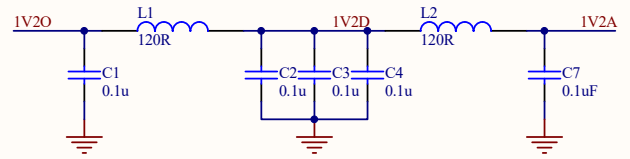
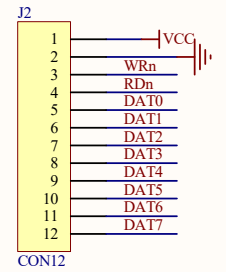
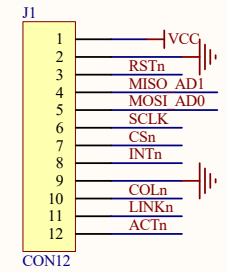
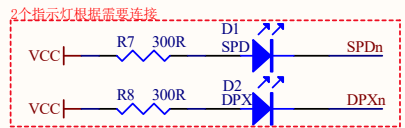

各去耦电容应尽量靠近W5100S

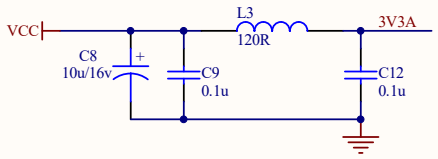

电源引脚附近放置0.1uF旁路电容, 减少电源噪声



项目名称 W5100S/W6100独立变压器
 公司网址 www.hschip.com
 联系电话 028-86127089 0755-86066647
 技术邮箱 support@hschip.com
 浩然电子自09年起一直蝉联WIZnet最佳代理商