

FC-1602-01

1 MECHANICAL

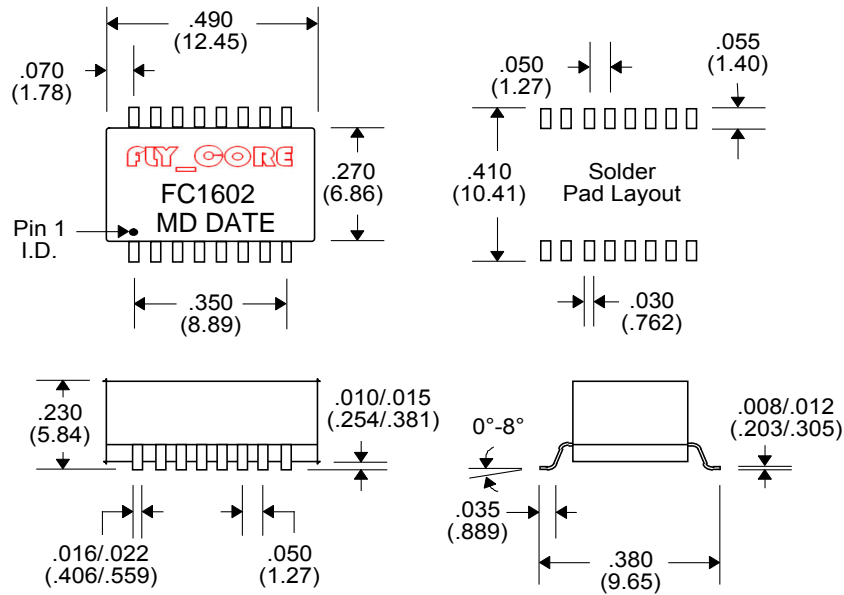

2 Schematics

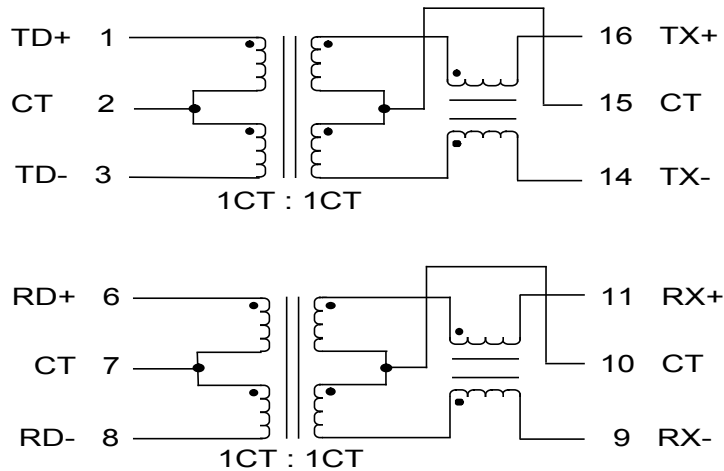

old No.	
original No.	
date	sign

REVISIONS			
REV.	DESCRIPTION	ECN NO.	DATE
A	FIRST RELEASE		2012-04-05



ELECTRICAL SPECIFICATIONS@25°C:

TURN RATIO(±2%): 1CT:1CT

INDUCTANCE(100KHz/100mV@8mA): 350uH MIN

Insertion Loss(dB MAX): -1.2dB(1-100MHz)

Return Loss(dB MIN):

-16dB(1-30MHz), -14dB(40MHz), -13dB(50MHz), -12dB(60-80MHz)

Crosstalk(dB MIN): -45dB(30MHz), -40dB(60MHz), -35dB(100MHz)

DCMR(dB MIN): -43dB(30MHz), -37dB(60MHz), -33dB(100MHz)

DC RESISTANCE BALANCE: ≤3.5%

HI-POT:4500Vrms/0.5mA/2Sec

OPERATING TEMPERATURE:-40°C TO +85°C

RoHS compliance:YES

上海飞芯电子科技有限公司		TITLE:	
		10/100BASE-TX VoIP Magnetics Modules	
APPROVALS	Date	Page	PART NO:
DRAWN BY:			
PROJ. ENG:		Total	www.ic-fly.com www.fly-core.com
APPROVED BY:			

PRODUCT TEST DATA (产品测试报告)

NO	1	2	3	4	5	6	7	8	9	10
SPEC										
URNS RATIO:										
PRI:SEC=1CT:1CT ±3%	OK	OK	OK	OK	OK					
HI-POT:										
PRI:SEC at 4500Vrms1mA	OK	OK	OK	OK	OK					
OCL(AT 100KHz, 100mV										
350uHMin.With8mA DC Bias)										
1-3	446	493	491	509	505					
6-8	454	439	495	406	481					
LK:(AT 100KHz, 0.1V)										
0.5 uH Max.										
1-3(16-14short)	0.19	0.15	0.20	0.24	0.22					
6-8(11-9short)	0.20	0.22	0.24	0.23	0.20					
Cw/w:(AT 100KHz, 0.1V)										
30 pF Max.										
5-13	45	43	40	49	41					
Cw/w:(AT 100KHz, 0.1V)										
30 pF Max.										
5-13	45	43	40	49	41					

MAIN TEST EQUIPMENT

- TOPWARD TPT-500 WITHSTANDING VOLTAGE TESTER
- HEWLETT PACKARD 4277A LCZ METER
- CHEN HWA 3250 AUTOMATIC TRANSFORMER TEST SYSTEM
- CHEN HWA 502A LOW-OHM METER
- RF NETWORK ANALYZERS HP8712ET

REPORT BY:	CHECKED BY:	APPROVED BY:	CUSTOMER:
Jack_Chen	SilceDeng	JamesTan	PART NO. : FC1602



FLY_CORE Semiconductor Inc.

REV.: A
PAGE: 1 OF 1